

PLUNGER ACTION

CP8



Material: Heavy gauge steel
Hardened pins and bushes

Finishing: Zinc plated body
Copper plated plunger

Supplied with: 10x50mm spindle

Max Holding pressure: 1000daN

Weight: 0.9Kgs

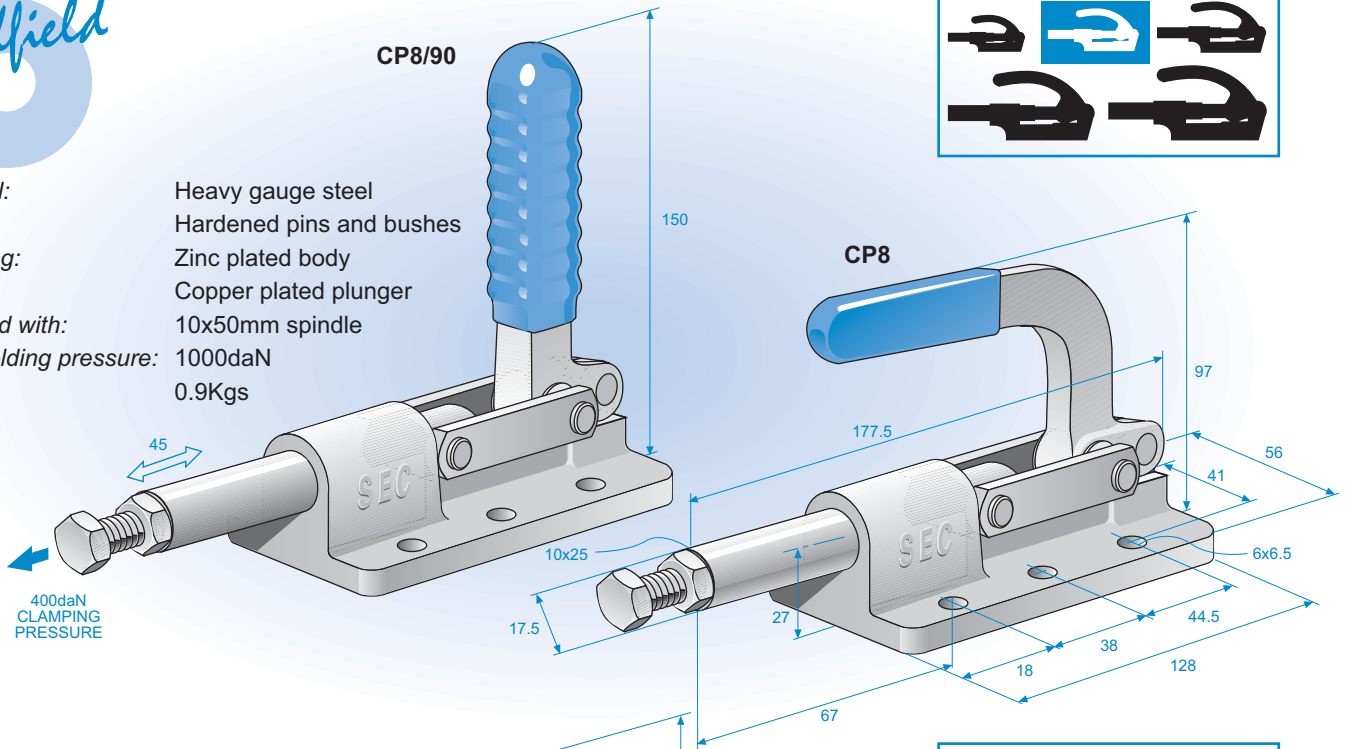

Material: Heavy gauge steel
Hardened pins and bushes

Finishing: Zinc plated body
Copper plated plunger

Supplied with: 12x60mm spindle

Max Holding pressure: 3000daN

Weight: 2Kgs

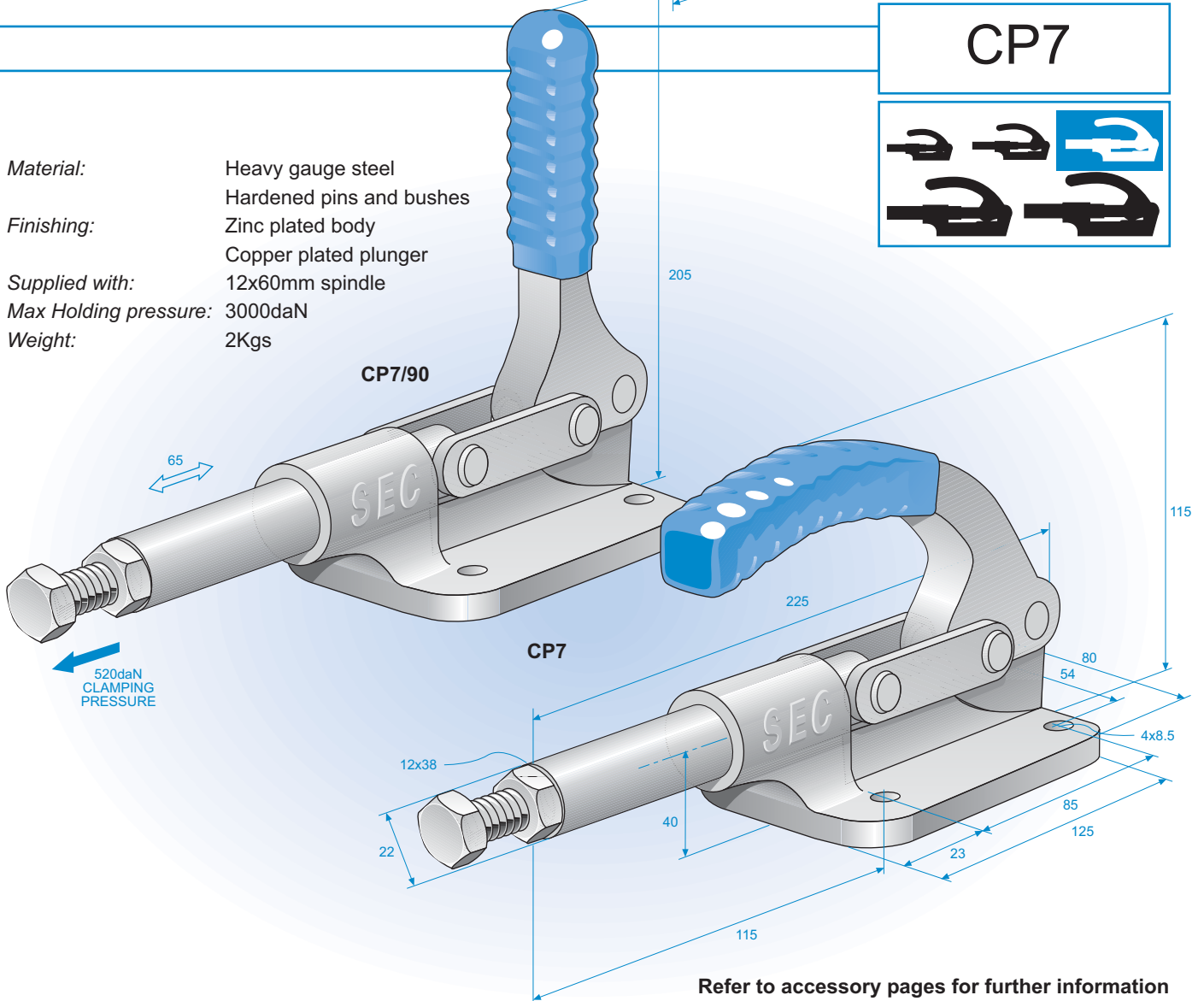

CP7

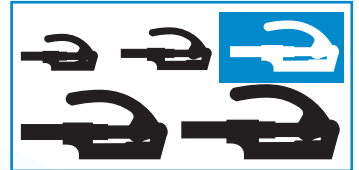

Refer to accessory pages for further information